

# UNIFLEX *Advanced*

Light, quiet all-rounder with wide range of applications\*

- Cost-effective cable carrier
- Weight-optimized chain geometry
- Particularly high torsional rigidity

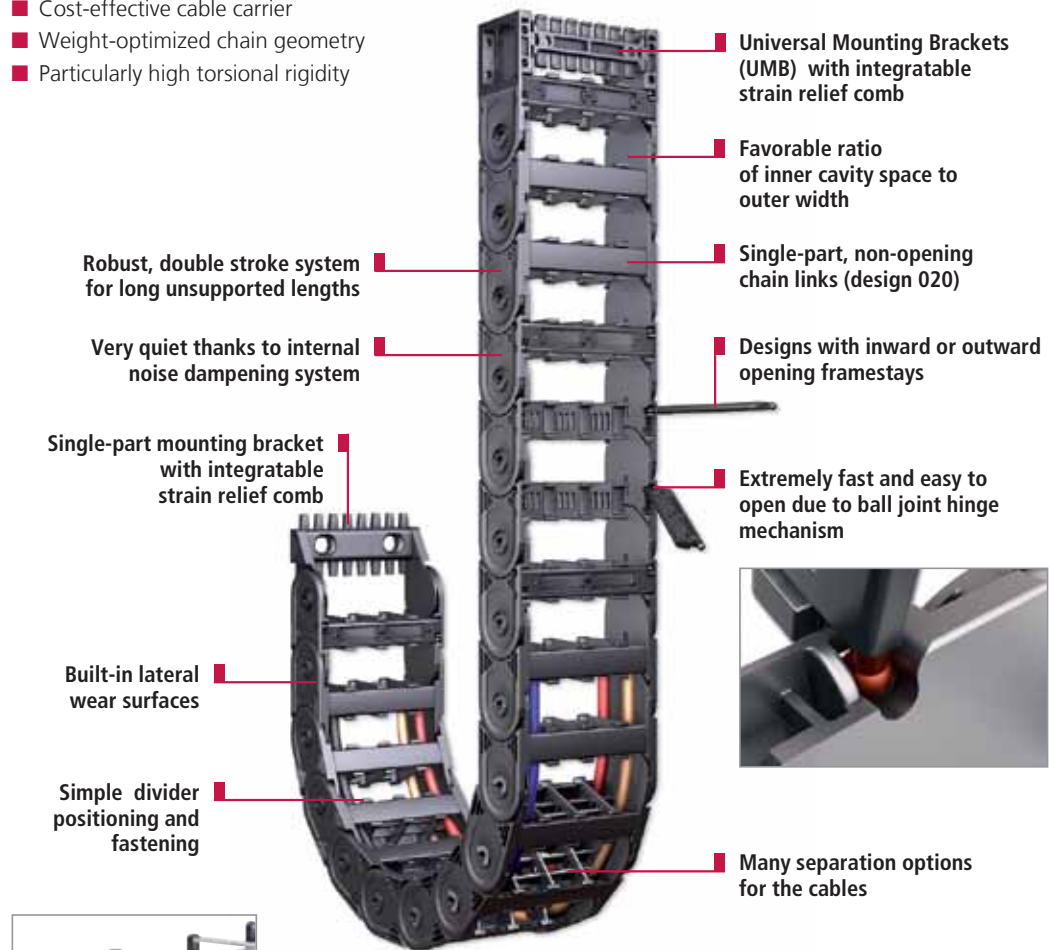

## UNIFLEX Advanced 1665 with cavity height extender frame stay

The extended height frame stay can be used to reliably route cables with a very large diameters, such as vacuum hoses, which are large and require more cavity space than the standard frame stay allows.

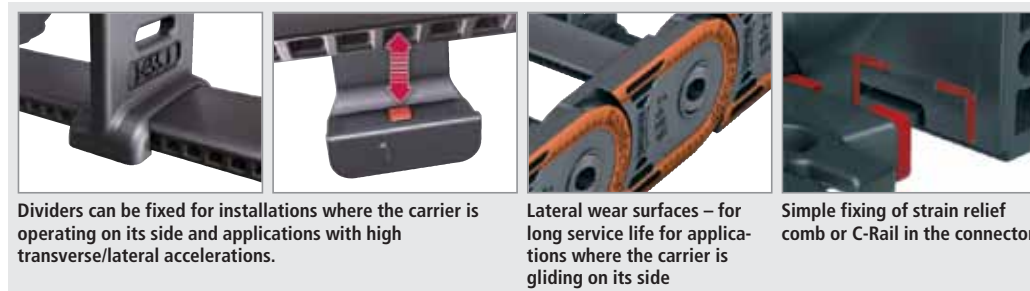

Dividers can be fixed for installations where the carrier is operating on its side and applications with high transverse/lateral accelerations.

Lateral wear surfaces – for long service life for applications where the carrier is gliding on its side

Simple fixing of strain relief comb or C-Rail in the connector

\* Some features can be different for certain types for design reasons. Our specialists are happy to advise you.



## GENERAL DATA

<b>E</b>	<b>CONOMIC</b>
<b>V</b>	<b>ALUE</b>
<b>A</b>	<b>DDED</b>
<b>7</b>	

A product group's EVA score is a general indicator that allows a customer to quickly and easily compare a product group's basic price, features, capabilities and value relative to other comparably sized products within the KS product range.

Download 3D CAD files, videos, updated product info & much more at:  
[www.kabelschlepp.com/uniflexadv.htm](http://www.kabelschlepp.com/uniflexadv.htm)

Dimensions in inches (mm)

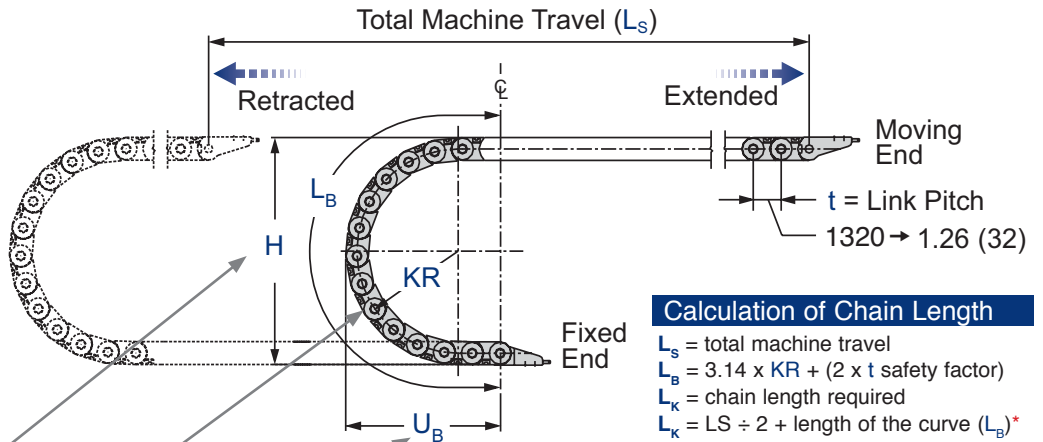

### Calculation of Chain Length

- $L_s$  = total machine travel
  - $L_B = 3.14 \times KR + (2 \times t \text{ safety factor})$
  - $L_K$  = chain length required
  - $L_K = L_s \div 2 + \text{length of the curve } (L_B)^*$
- \* Assumes the Fixed Point is located at the Center of the Total Machine Travel.

## Technical Data

Series	Mounting Height <b>H</b>	Bend Radius <b>KR</b>	Depot <b>U<sub>B</sub></b>	Loop Length <b>L<sub>B</sub></b>
<b>1320 Design 020</b>				
Option A	3.23 (82)	1.10 (28)	2.86 (73)	5.98 (152)
Option B	4.02 (102)	1.50 (38)	3.26 (83)	7.24 (184)
Option C	4.80 (122)	1.89 (48)	3.67 (93)	8.46 (215)
Option D	6.93 (176)	2.95* (75)*	4.72 (120)	11.81 (300)
Option E	8.90 (226)	3.94* (100)*	5.71 (145)	14.92 (379)
Option F	10.87 (276)	4.92* (125)*	6.69 (170)	17.99 (457)

\* special order, available upon request

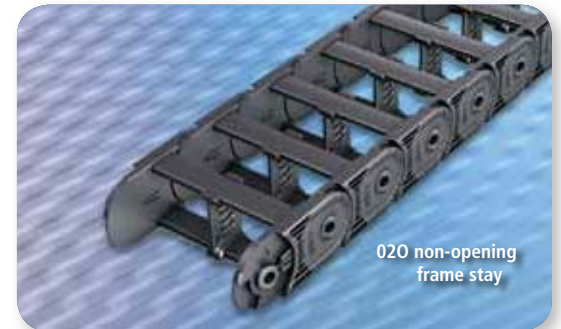

### Self-Supporting Lengths

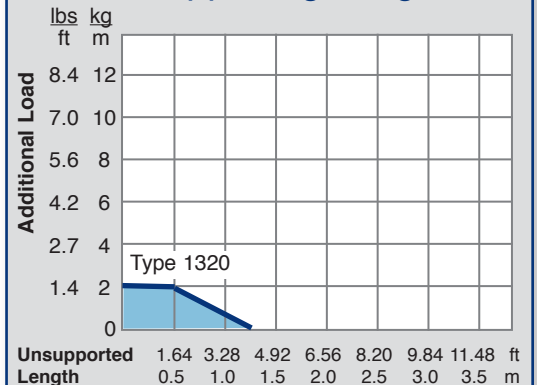

#### Extended Travel:

When application travel exceeds the self-supporting length of the carrier, UNIFLEX Advanced carrier systems are designed to glide on themselves in a guide channel.



For more information on extended travel systems, see pages 02.27 - 02.36

## How To Order

1-800-443-4216

Number of Systems Req. x Carrier Type + Carrier Design + Cavity Width (B<sub>i</sub>) + Bend Radius x # of Links Length + Type & Position Brackets + Dividers (#vert / #horz)

15 x 1320 · 020 · 038 · 028 x 72 Links + FAMU + 2v/1h

### Design 020 - non-opening links

#### 1320.020.038

Chain Weight:  
0.27 lbs/ft  
(0.40 kg/m)

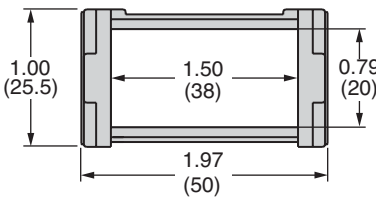

#### 1320.020.050

Chain Weight:  
0.29 lbs/ft  
(0.43 kg/m)

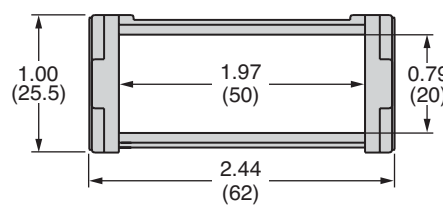

020 non-opening link design

BASIC-LINE

### 1320 Cavity Partitioning Options:

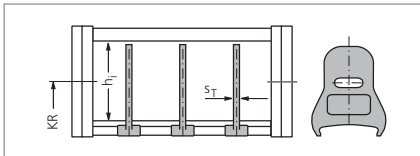

In the standard version, the divider systems are mounted on every second chain link.

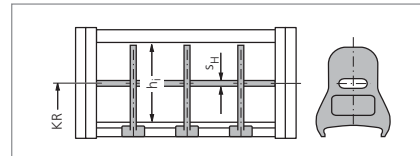

In the standard version, the divider systems are mounted on every second chain link.

#### Divider system TS 0 (Type 1320)

Type	hi inches (mm)	ST inches (mm)
1320	0.79 (20)	0.08 (2)

The dividers can be moved in the cross section.

#### Divider system TS 1 (Type 1320)

with continuous height subdivision made of aluminum

Type	hi in (mm)	ST in (mm)	SH in (mm)
1320	0.79 (20)	0.08 (2)	0.09 (2.4)

The dividers can be moved in the cross section.



### 1320 Mounting Bracket Options:

#### Connection dimensions for Type 1320

Connecting elements with strain relief combs on one side

##### ZLK - A integrated strain relief combs

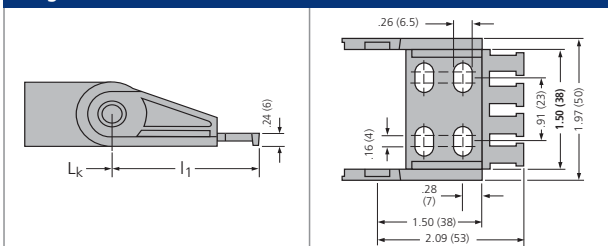

Type	Bi	Bk	nZ
1320 ... .38	1.50 (38)	1.97 (50)	0.16 (4)

Dimensions in inches (mm)

Short brackets without strain relief are also available for restricted installation conditions. Please contact us.

The dimensions of the fixed end and moving end brackets are identical.



## GENERAL DATA

<b>E</b>	<b>CONOMIC</b>
<b>V</b>	<b>ALUE</b>
<b>A</b>	<b>DDED</b>
<b>7</b>	
<p>A product group's EVA score is a general indicator that allows a customer to quickly and easily compare a product group's basic price, features, capabilities and value relative to other comparably sized products within the KS product range.</p>	
<p>Download 3D CAD files, videos, updated product info &amp; much more at:  <a href="http://www.kabelschlepp.com/uniflexadv.htm">www.kabelschlepp.com/uniflexadv.htm</a></p>	

Dimensions in inches (mm)

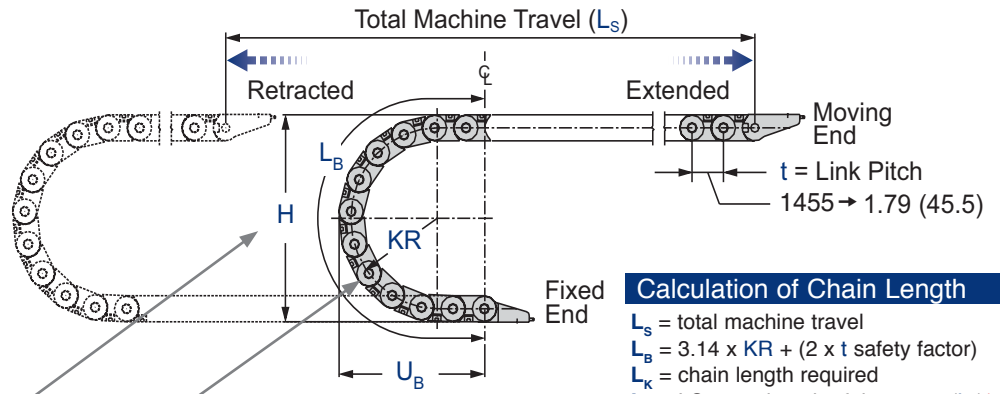

### Calculation of Chain Length

- $L_s$  = total machine travel
  - $L_b = 3.14 \times KR + (2 \times t \text{ safety factor})$
  - $L_k$  = chain length required
  - $L_k = L_s \div 2 + \text{length of the curve } (L_b)^*$
- \* Assumes the Fixed Point is located at the Center of the Total Machine Travel.

## Technical Data

Series	Mounting Height <b>H</b>	Bend Radius <b>KR</b>	Depot <b>U<sub>B</sub></b>	Loop Length <b>L<sub>B</sub></b>
<b>1455</b> Design 030/040				
Option A	5.51 (140)	2.05 (52)	4.57 (116)	10.00 (254)
Option B	6.54 (166)	2.56 (65)	5.08 (129)	11.61 (295)
Option C	8.90 (226)	3.74 (95)	6.26 (159)	15.35 (389)
Option D	11.26 (286)	4.92 (125)	7.44 (189)	19.06 (484)
Option E	13.23 (336)	5.91 (150)	8.43 (214)	22.13 (562)
Option F	15.59 (396)	7.09 (180)	9.61 (244)	25.87 (656)
Option G	17.17 (436)	7.87 (200)	10.39 (264)	28.35 (719)
Option H	19.13 (486)	8.86 (225)	11.38 (289)	31.42 (798)

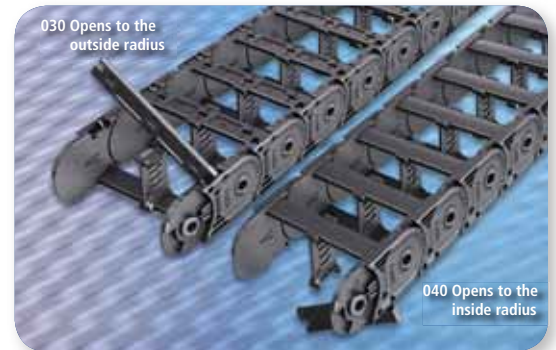

### Self-Supporting Lengths

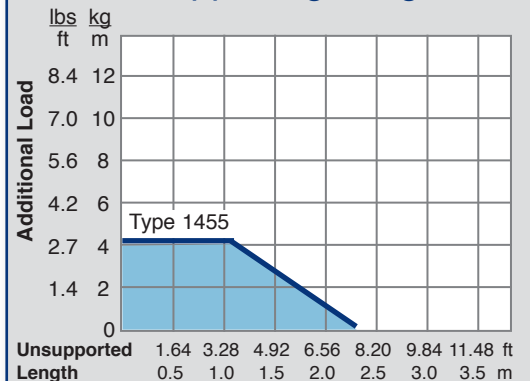

**Extended Travel:**  
When application travel exceeds the self-supporting length of the carrier, UNIFLEX Advanced carrier systems are designed to glide on themselves in a guide channel.



For more information on extended travel systems, see pages 02.27 - 02.36

## How To Order

1-800-443-4216

Number of Systems Req. x Carrier Type + Carrier Design + Cavity Width (B<sub>i</sub>) + Bend Radius x # of Links Length + Type & Position Brackets + Dividers (#vert / #horz)

**20 x 1455 · 030 · 078 · 180 x 90 Links + FH/MH + 3v/0h**

### Design 030 - opens on the outside radius

### Series 1455

#### 1455.030.025

Chain Weight:  
0.49 lbs/ft  
(0.73 kg/m)

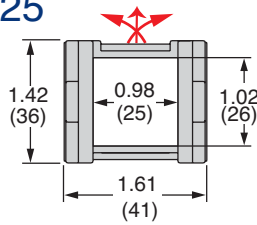

1455.030 open style design has hinged-opening bars that open from either side of the outside radius for easy cable and/or hose installation and service.



#### 1455.030.038

Chain Weight:  
0.50 lbs/ft  
(0.75 kg/m)

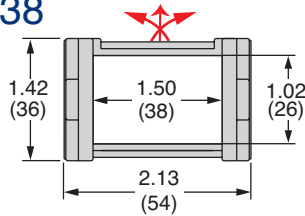

#### 1455.030.058

Chain Weight:  
0.54 lbs/ft  
(0.80 kg/m)

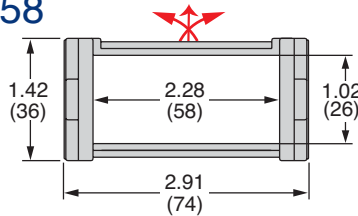

#### 1455.030.078

Chain Weight:  
0.59 lbs/ft  
(0.88 kg/m)

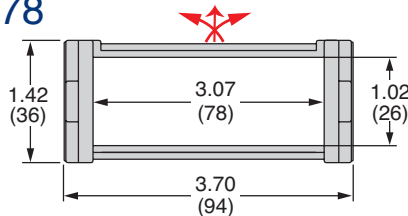

#### 1455.030.103

Chain Weight:  
0.66 lbs/ft  
(0.98 kg/m)

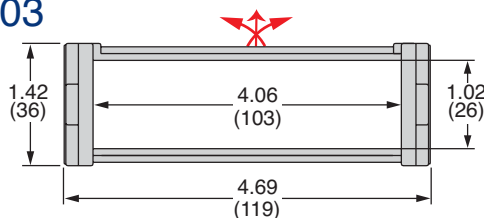

### Design 040 - opens on the inside radius

### Series 1455

#### 1455.040.025

Chain Weight:  
0.49 lbs/ft  
(0.73 kg/m)

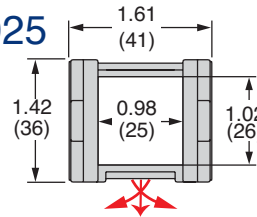

1455.040 open style design has hinged-opening bars that open from either side of the inside radius for easy cable and/or hose installation and service.



#### 1455.040.038

Chain Weight:  
0.50 lbs/ft  
(0.75 kg/m)

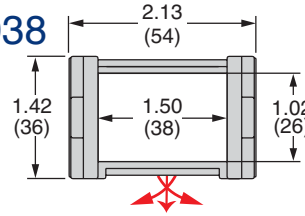

#### 1455.040.058

Chain Weight:  
0.54 lbs/ft  
(0.80 kg/m)

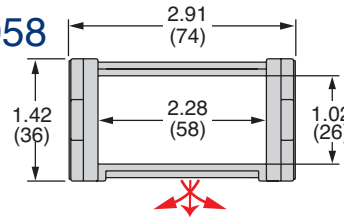

#### 1455.040.078

Chain Weight:  
0.59 lbs/ft  
(0.88 kg/m)

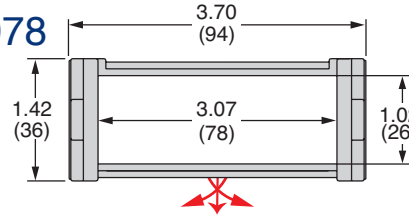

#### 1455.040.103

Chain Weight:  
0.66 lbs/ft  
(0.98 kg/m)

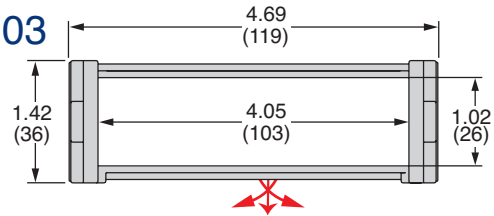

#### Mounting Brackets

For drawings and dimensions of available mounting bracket options: See pages 07.12 - 07.14



#### Cavity Partitioning

For drawings and dimensions of available cavity partitioning options: See pages 07.10 - 07.11



#### Design 20 with non-opening links also available

Perfect for use with surging, high-pressure hoses.. Special order - consult factory.





## GENERAL DATA

<b>E</b>	<b>CONOMIC</b>
<b>V</b>	<b>ALUE</b>
<b>A</b>	<b>DDED</b>
<b>7</b>	
<p>A product group's EVA score is a general indicator that allows a customer to quickly and easily compare a product group's basic price, features, capabilities and value relative to other comparably sized products within the KS product range.</p>	
<p>Download 3D CAD files, videos, updated product info &amp; much more at:  <a href="http://www.kabelschlepp.com/uniflexadv.htm">www.kabelschlepp.com/uniflexadv.htm</a></p>	

Dimensions in inches (mm)

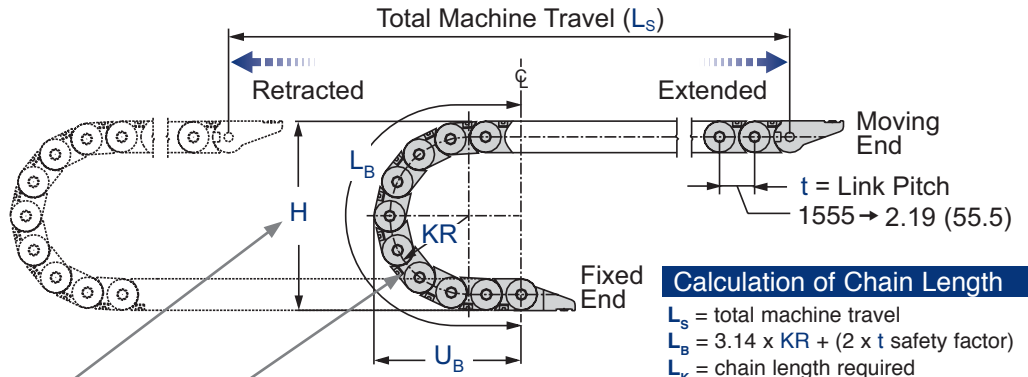

### Calculation of Chain Length

- $L_s$  = total machine travel
  - $L_b = 3.14 \times KR + (2 \times t \text{ safety factor})$
  - $L_k$  = chain length required
  - $L_k = L_s \div 2 + \text{length of the curve } (L_b)^*$
- \* Assumes the Fixed Point is located at the Center of the Total Machine Travel.

## Technical Data

Series	Mounting Height <b>H</b>	Bend Radius <b>KR</b>	Depot <b>U<sub>B</sub></b>	Loop Length <b>L<sub>B</sub></b>
<b>1555</b> Design 030/040				
Option A	6.93 (176)	2.48 (63)	5.67 (144)	12.17 (309)
Option B	8.27 (210)	3.15 (80)	6.34 (161)	14.25 (362)
Option C	9.84 (250)	3.94 (100)	7.13 (181)	16.73 (425)
Option D	11.81 (300)	4.92 (125)	8.11 (206)	19.84 (504)
Option E	14.57 (370)	6.30 (160)	9.49 (241)	24.17 (614)
Option F	17.72 (450)	7.87 (200)	11.06 (281)	29.13 (740)
Option G	20.08 (510)	9.06 (230)	12.24 (311)	32.83 (834)

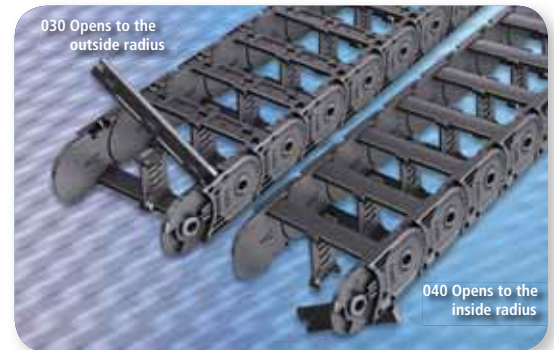

### Self-Supporting Lengths

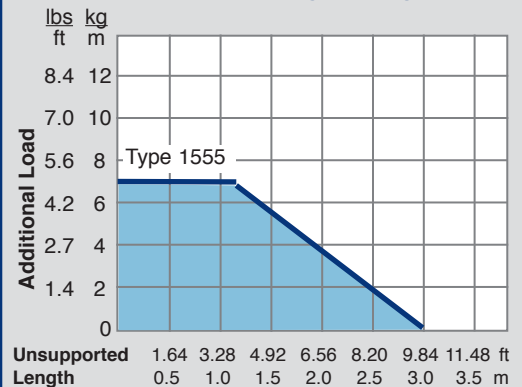

**Extended Travel:**  
When application travel exceeds the self-supporting length of the carrier, UNIFLEX Advanced carrier systems are designed to glide on themselves in a guide channel.



For more information on extended travel systems, see pages 02.27 - 02.36

## How To Order

1-800-443-4216

Number of Systems Req. x Carrier Type + Carrier Design + Cavity Width (Bj) + Bend Radius x # of Links Length + Type & Position Brackets + Dividers (#vert / #horz)

**8 x 1555 · 040 · 125 · 125 x 53 Links + FU/MU + 3v/1h**

### Design 030 - opens on the outside radius

### Series 1555

#### 1555.030.050

Chain Weight:  
0.76 lbs/ft  
(1.13 kg/m)

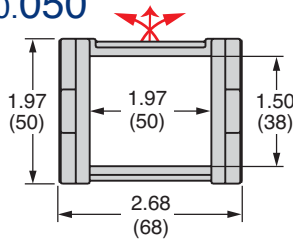

1555.030 open style design has hinged-opening bars that open from either side of the outside radius for easy cable and/or hose installation and service.

#### 1555.030.075

Chain Weight:  
0.83 lbs/ft  
(1.23 kg/m)

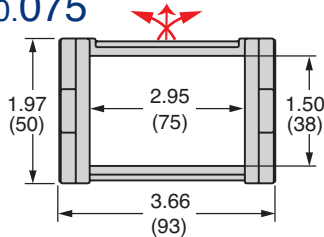

#### 1555.030.100

Chain Weight:  
0.89 lbs/ft  
(1.32 kg/m)

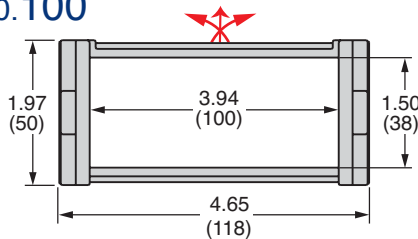

#### 1555.030.125

Chain Weight:  
0.95 lbs/ft  
(1.42 kg/m)

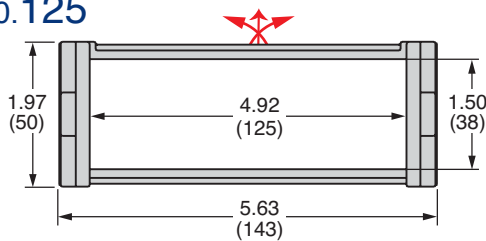

#### 1555.030.150

Chain Weight:  
1.01 lbs/ft  
(1.51 kg/m)

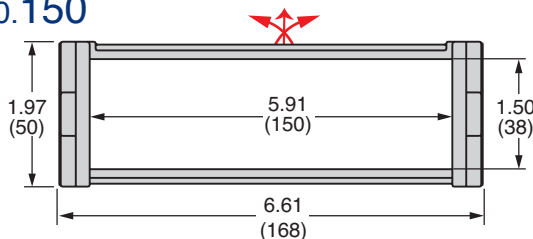

### Design 040 - opens on the inside radius

### Series 1555

#### 1555.040.050

Chain Weight:  
0.76 lbs/ft  
(1.13 kg/m)

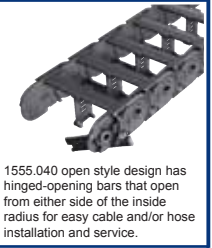
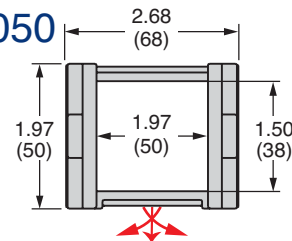

1555.040 open style design has hinged-opening bars that open from either side of the inside radius for easy cable and/or hose installation and service.

#### 1555.040.075

Chain Weight:  
0.83 lbs/ft  
(1.23 kg/m)

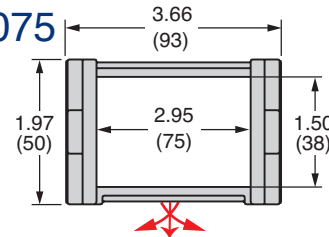

#### 1555.040.100

Chain Weight:  
0.89 lbs/ft  
(1.32 kg/m)

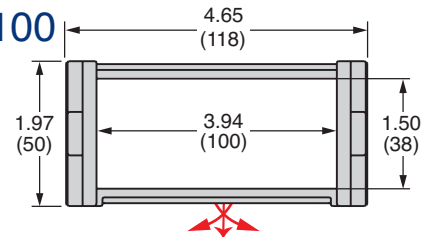

#### 1555.040.125

Chain Weight:  
0.95 lbs/ft  
(1.42 kg/m)

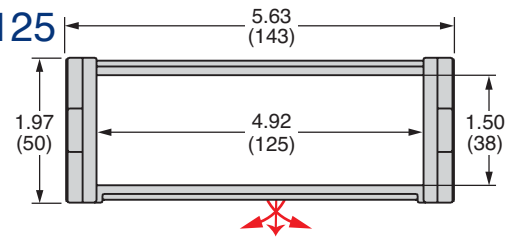

#### 1555.040.150

Chain Weight:  
1.01 lbs/ft  
(1.51 kg/m)

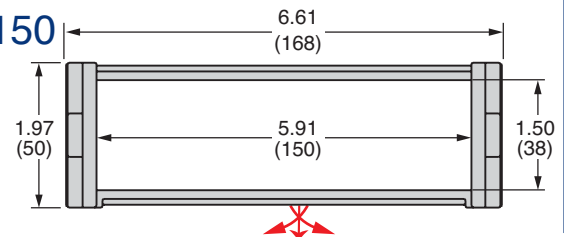

#### Mounting Brackets

For drawings and dimensions of available mounting bracket options: See pages 07.12 - 07.14



#### Cavity Partitioning

For drawings and dimensions of available cavity partitioning options: See pages 07.10 - 07.11



#### Design 20 with non-opening links also available

Perfect for use with surging, high-pressure hoses.. Special order - consult factory.





## GENERAL DATA

<b>E</b>	<b>CONOMIC</b>
<b>V</b>	<b>ALUE</b>
<b>A</b>	<b>DDED</b>
<b>7</b>	
<p>A product group's EVA score is a general indicator that allows a customer to quickly and easily compare a product group's basic price, features, capabilities and value relative to other comparably sized products within the KS product range.</p>	
<p>Download 3D CAD files, videos, updated product info &amp; much more at:  <a href="http://www.kabelschlepp.com/uniflexadv.htm">www.kabelschlepp.com/uniflexadv.htm</a></p>	

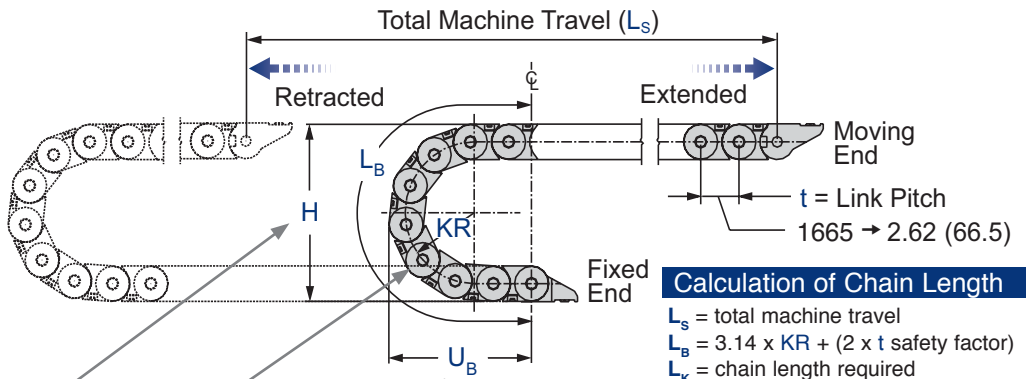

### Calculation of Chain Length

- $L_S$  = total machine travel
  - $L_B = 3.14 \times KR + (2 \times t \text{ safety factor})$
  - $L_K$  = chain length required
  - $L_K = L_S \div 2 + \text{length of the curve } (L_B)^*$
- \* Assumes the Fixed Point is located at the Center of the Total Machine Travel.

Dimensions in inches (mm)

## Technical Data

Series	Mounting Height <b>H</b>	Bend Radius <b>KR</b>	Depot <b>U<sub>B</sub></b>	Loop Length <b>L<sub>B</sub></b>
<b>1665</b> Design 030/040				
Option A	8.27 (210)	2.95 (75)	6.77 (172)	14.53 (369)
Option B	10.24 (260)	3.94 (100)	7.76 (197)	17.64 (448)
Option C	11.81 (300)	4.72 (120)	8.54 (217)	20.08 (510)
Option D	13.39 (340)	5.51 (140)	9.33 (237)	22.56 (573)
Option E	18.11 (460)	7.87 (200)	11.69 (297)	30.00 (762)
Option F	22.05 (560)	9.84 (250)	13.66 (347)	36.18 (919)
Option G	25.98 (660)	11.81 (300)	15.63 (397)	42.36 (1076)



### Self-Supporting Lengths

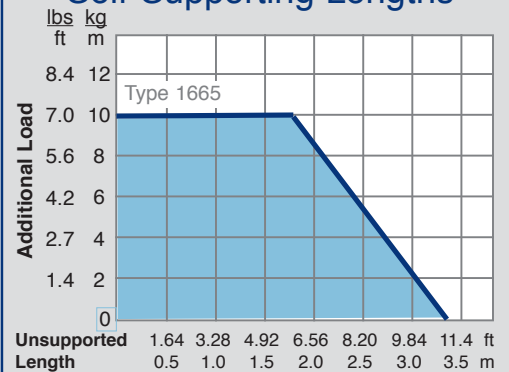

#### Extended Travel:

When application travel exceeds the self-supporting length of the carrier, UNIFLEX carrier systems are designed to glide on themselves in a guide channel.



For more information on extended travel systems, see pages 02.27 - 02.36

## How To Order

1-800-443-4216

Number of Systems Req. x Carrier Type + Carrier Design + Cavity Width (B<sub>i</sub>) + Bend Radius x # of Links Length + Type & Position Brackets + Dividers (#vert / #horz)

**50 x 1665 · 030 · 125 · 140 x 38 Links + FA/MA + 3v/2h**



**Design 030** - opens on the outside radius  
**Series 1665**

**1665.030.050**

Chain Weight:  
1.12 lbs/ft  
(1.67 kg/m)

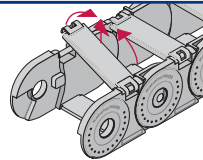
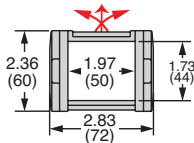

1665.030 open style design has hinged-opening bars that open from either side of the outside radius for easy cable and/or hose installation and service.

**1665.030.075**

Chain Weight:  
1.21 lbs/ft  
(1.80 kg/m)

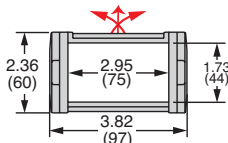

**1665.030.100**

Chain Weight:  
1.29 lbs/ft  
(1.92 kg/m)

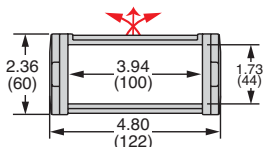

**1665.030.125**

Chain Weight:  
1.38 lbs/ft  
(2.06 kg/m)

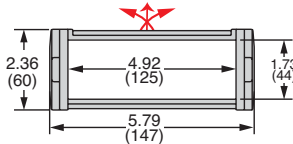

**1665.030.150**

Chain Weight:  
1.46 lbs/ft  
(2.18 kg/m)

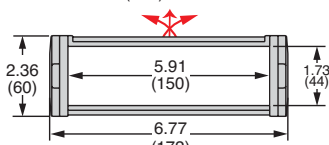

**1665.030.175**

Chain Weight:  
1.55 lbs/ft  
(2.31 kg/m)

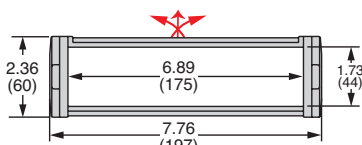

**1665.030.200**

Chain Weight:  
1.63 lbs/ft  
(2.43 kg/m)

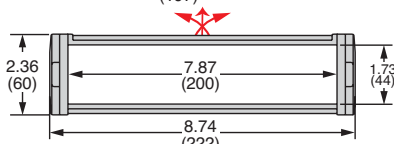

**1665.030.225**

Chain Weight:  
1.73 lbs/ft  
(2.57 kg/m)

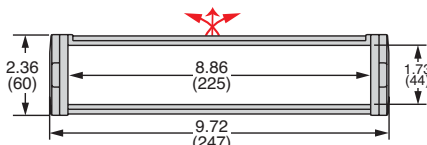

**1665.030.250**

Chain Weight:  
1.81 lbs/ft  
(2.70 kg/m)

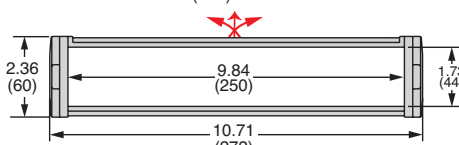

**Design 040** - opens on the inside radius  
**Series 1665**

**1665.040.050**

Chain Weight:  
1.12 lbs/ft  
(1.67 kg/m)

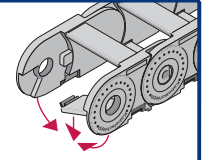
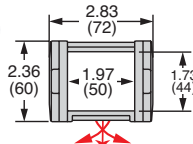

1665.040 open style design has hinged-opening bars that open from either side of the inside radius for easy cable and/or hose installation and service.

**1665.040.075**

Chain Weight:  
1.21 lbs/ft  
(1.80 kg/m)

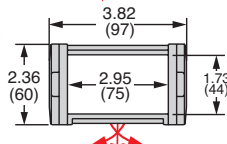

**1665.040.100**

Chain Weight:  
1.29 lbs/ft  
(1.92 kg/m)

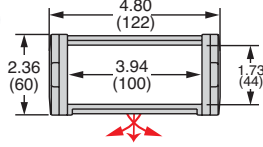

**1665.040.125**

Chain Weight:  
1.38 lbs/ft  
(2.06 kg/m)

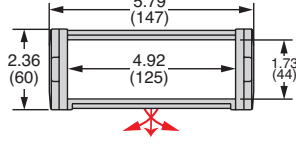

**1665.040.150**

Chain Weight:  
1.46 lbs/ft  
(2.18 kg/m)

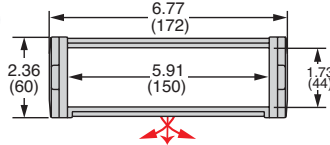

**1665.040.175**

Chain Weight:  
1.55 lbs/ft  
(2.31 kg/m)

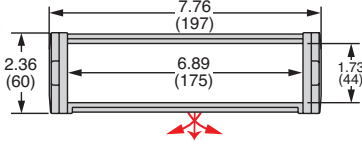

**1665.040.200**

Chain Weight:  
1.63 lbs/ft  
(2.43 kg/m)

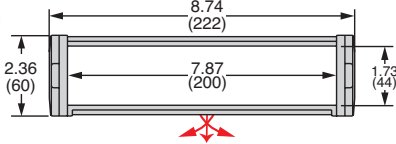

**1665.040.225**

Chain Weight:  
1.73 lbs/ft  
(2.57 kg/m)

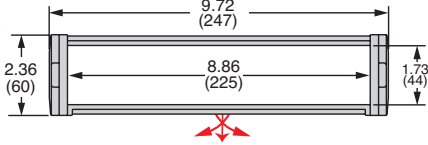

**1665.040.250**

Chain Weight:  
1.81 lbs/ft  
(2.70 kg/m)

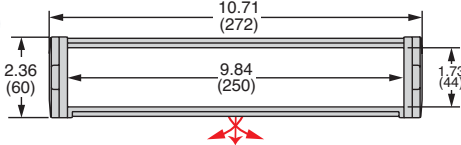

**Mounting Brackets**

For drawings and dimensions of available mounting bracket options: See pages 07.12 - 07.14



**Cavity Partitioning**

For drawings and dimensions of available cavity partitioning options: See pages 07.10 - 07.11



**Design 20 with non-opening links also available**

Perfect for use with surging, high-pressure hoses.. Special order - consult factory.



BASIC-LINE

UNIFLEX Advanced

07



## 1455, 1555, and 1665 Cavity Partitioning Options:

### Fixing of the dividers

In the standard version, dividers or the complete divider system (dividers with height separation) can be moved in the cross section (**Version A**).

Fixed dividers are available for applications with transverse accelerations and where the carrier is rotated 90° for side mound operation. (**Version B**). If the fixed installation version is desired, please state this on the order.

### Version A (Standard)

Divider movable



### Version B

Divider fixed in 2.5 mm steps

With fixed dividers, fixing is by means of arresting cams in the foot of the divider.



■ Locking profile in the crossbar



■ Divider with arresting cams

### Divider system TS 0

Type	$h_i$	Version A			Version B			
		$S_T$	$a_T \text{ min}$	$a_x \text{ min}$	$S_T$	$a_T \text{ min}$	$a_x \text{ min}$	$a_x \text{ section}$
1455	1.02 (26)	0.08 (2.0)	0.14 (3.5)	0.28 (7)	0.08 (2.0)	0.16/0.20* (4/5)*	0.30 (7.5)	0.10 (2.5)
1555	1.50 (38)	0.10 (2.5)	0.20 (5.0)	0.39 (10)	0.10 (2.5)	0.20 (5)	0.39 (10)	0.10 (2.5)
1665	1.73 (44)	0.12 (3.0)	0.20 (5.0)	0.39 (10)	0.12 (3.0)	0.20 (5)	0.39 (10)	0.10 (2.5)

\*  $a_T \text{ min} = 0.16$  in for  $B_i = 1.50, 2.28, 3.07, 4.06$      $a_T \text{ min} = 0.20$  for  $B_i = 0.98$   
 \*  $a_T \text{ min} = (4 \text{ mm})$  for  $B_i = (38), (58), (78), (103)$      $a_T \text{ min} = (5 \text{ mm})$  for  $B_i = (25)$

Dimensions in inches (mm)

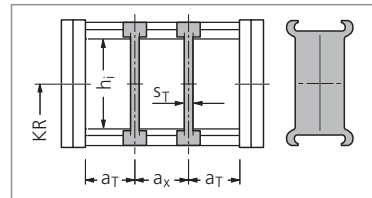

### Divider system TS 1 for Design 030/040

with continuous height subdivision made of aluminum

Type	$h_i$	Version A			Version B				$S_H$	$h_1$	$h_2$
		$S_T$	$a_T \text{ min}$	$a_x \text{ min}$	$S_T$	$a_T \text{ min}$	$a_x \text{ min}$	$a_x \text{ section}$			
1455	1.02 (26)	0.08 (2.0)	0.14 (3.5)	0.28 (7)	0.08 (2.0)	0.16/0.20* (4/5)*	0.30 (7.5)	0.10 (2.5)	0.08 (2)	0.39 (10)	—
1555	1.50 (38)	0.10 (2.5)	0.20 (5)	0.39 (10)	0.10 (2.5)	0.20 (5)	0.39 (10)	0.10 (2.5)	0.16 (4)	0.55 (14)	—
1665	1.73 (44)	0.12 (3.0)	0.20 (5)	0.39 (10)	0.12 (3.0)	0.20 (5)	0.39 (10)	0.10 (2.5)	0.16 (4)	0.55 (14)	1.10 (28)

\*  $a_T \text{ min} = 0.16$  in for  $B_i = 1.50, 2.28, 3.07, 4.06$      $a_T \text{ min} = 0.20$  for  $B_i = 0.98$   
 \*  $a_T \text{ min} = (4 \text{ mm})$  for  $B_i = (38), (58), (78), (103)$      $a_T \text{ min} = (5 \text{ mm})$  for  $B_i = (25)$

Dimensions in inches (mm)

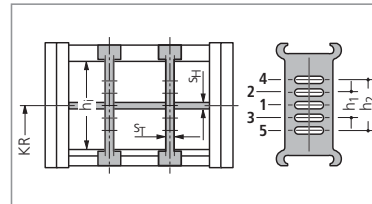



**Divider system TS 3 with section subdivision, partitions made of plastic**

Type	$h_i$	$S_T$	$a_T$ min	$a_x$ min	$S_H$	$h_1$	$h_2$
1455	1.02 (26)	0.20 (5)	0.14 (3.5)	0.28 (7)	0.09 (2.4)	0.39 (10)	–
1555	1.50 (38)	0.20 (5)	0.20 (5)	0.39 (10)	0.09 (2.4)	0.47 (12)	–
1665	1.73 (44)	0.31 (8)	0.20 (5)	0.39 (10)	0.16 (4.0)	0.55 (14)	1.10 (28)

Dimensions in inches (mm)

The dividers are fixed by the partitions, the complete divider system is movable.

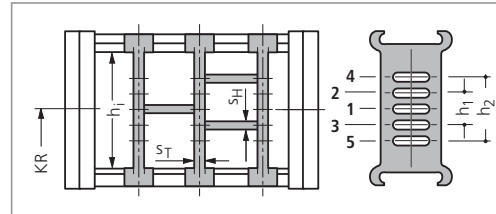

In the standard version, the divider systems are mounted on every second chain link.

BASIC-LINE

**Dimensions of the plastic partitions for TS 3**

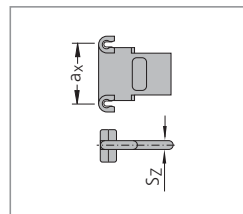

**Types 1455 and 1555**

$S_z$	$a_x$ (Center to center distance, dividers)									
0.09 (2.4)	0.59 (15)	0.79 (20)	0.98 (25)	1.18 (30)	1.38 (35)	1.57 (40)	1.77 (45)	2.17 (55)	2.56 (65)	2.95 (75)

Dimensions in inches (mm)

**Type 1665**

$S_z$	$a_x$ (Center to center distance, dividers)									
0.16 (4)	0.63 (16)	0.71 (18)	0.91 (23)	1.10 (28)	1.26 (32)	1.30 (33)	1.50 (38)	1.69 (43)	1.89 (48)	2.28 (58)
	2.52 (64)	2.68 (68)	3.07 (78)	3.15 (80)	3.46 (88)	3.78 (96)	4.41 (112)			

Dimensions in inches (mm)

For type 1665, aluminum partitions in 1 mm width increments are available.

UNIFLEX Advanced

07



## 1455, 1555, and 1665 Standard Mounting Bracket Options:

### Connection dimensions for Type 1455

Connecting elements with strain relief combs on both sides

#### ZLK - A integrated strain relief combs

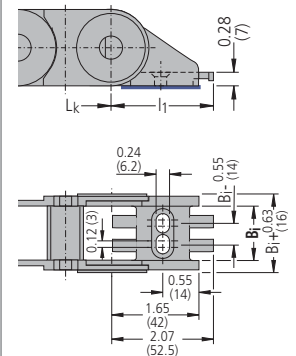

For chain width  
 $B_i = 0.98$  inches (25 mm)

#### ZLK - L screwable strain relief combs

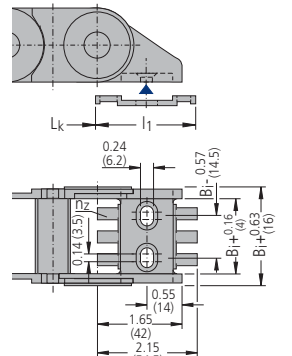

For chain width  
 $B_i = 1.50 - 4.06$  inches (38 - 103 mm)

Type	$B_i$	$B_k$	$n_z$
1455 ... .25	0.98 (25)	1.61 (41)	2
1455 ... .38	1.50 (38)	2.13 (54)	3
1455 ... .58	2.28 (58)	2.91 (74)	4
1455 ... .78	3.07 (78)	3.70 (94)	6
1455 ... .103	4.06 (103)	4.69 (119)	8

Dimensions in inches (mm)

The dimensions of the fixed end and moving end bracket are identical.

### Connection dimensions for Type 1555

Connecting elements with strain relief combs on both sides

#### ZLK - L screwable strain relief combs

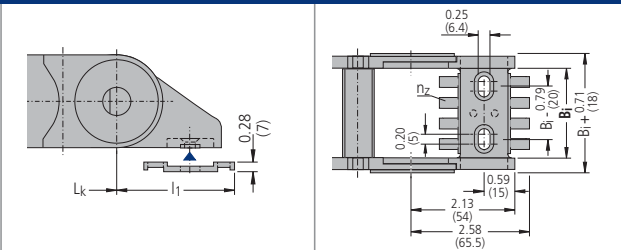

The dimensions of the fixed end and moving end bracket are identical.

Type	$B_i$	$B_k$	$n_z$
1555 ... .50	1.97 (50)	2.68 (68)	4
1555 ... .75	2.95 (75)	3.66 (93)	6
1555 ... .100	3.94 (100)	4.65 (118)	8
1555 ... .125	4.92 (125)	5.63 (143)	10
1555 ... .150	5.91 (150)	6.61 (168)	12

Dimensions in inches (mm)

For chain width  $B_i = 3.54$ " (90 mm) mounting brackets made of steel are available.

### Connection dimensions for Type 1665

Connecting elements with strain relief combs on both sides

#### ZLK - L screwable strain relief combs

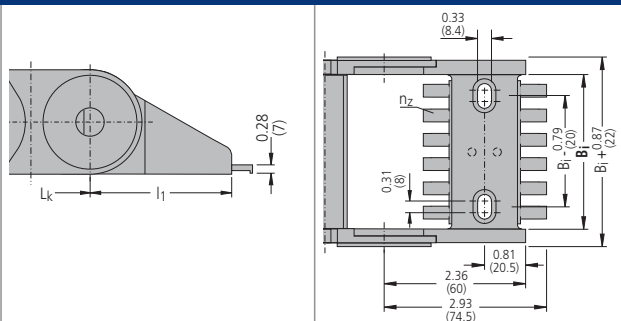

The dimensions of the fixed end and moving end bracket are identical.

Type	$B_i$	$B_k$	$n_z$
1665 ... .50	1.97 (50)	2.83 (72)	4
1665 ... .75	2.95 (75)	3.82 (97)	6
1665 ... .100	3.94 (100)	4.80 (122)	8
1665 ... .125	4.92 (125)	5.79 (147)	10
1665 ... .150	5.91 (150)	6.77 (172)	12
1665 ... .175	6.89 (175)	7.76 (197)	14
1665 ... .200	7.97 (200)	8.74 (222)	16
1665 ... .225	8.86 (225)	9.72 (247)	18
1665 ... .250	9.84 (250)	10.71 (272)	20

Dimensions in inches (mm)

## Strain relief devices for plastic connectors

### ZLK – A

Connecting elements with integrated strain relief combs on both sides (ZLK – A)

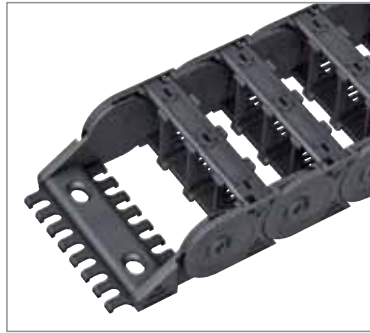

### ZLK – L

Connecting elements with screw-on type strain relief combs (ZLK – L)

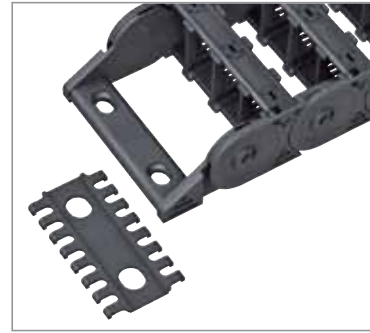

The strain relief combs are generally supplied with the connecting elements. The combs are either clipped to the end connectors and bolted together with them, or screwed on at the desired intervals by using additional boreholes, behind the connecting elements.

## Types 1455, 1555 and 1665

### Connection variants

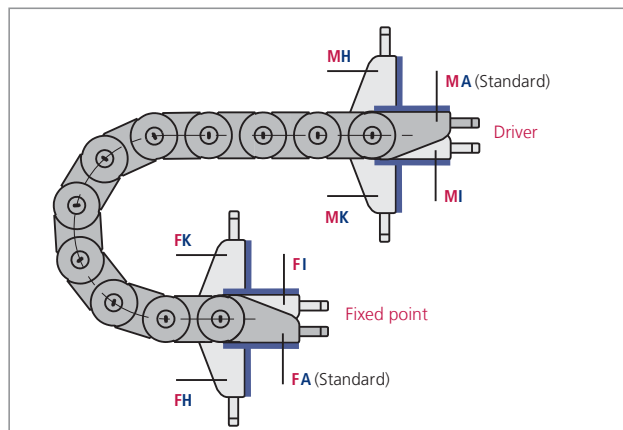

#### Connection point

- M** – Driven End
- F** – Fixed End

#### Connection type

- A** – Mounting surface outside (standard)
- I** – Mounting surface inside
- H** – Mounting surface, rotated 90° to the outside
- K** – Mounting surface, rotated 90° to the inside

In the standard version, the brackets are mounted with the mounting surface on the outside radius (FA/MA).

When ordering please specify the desired bracket type and configuration

The mounting bracket configuration can subsequently be altered simply by varying the bracket position.



## 1455, 1555, and 1665 Universal Mounting Bracket (UMB) Options:

### Universal mounting brackets

With plastic UMBs (Universal Mounting Brackets), you can easily connect the UNIFLEX **from above**, **from below**, or **from the front of the bracket**.



#### UNIFLEX 1455

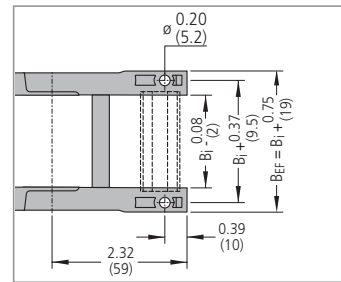
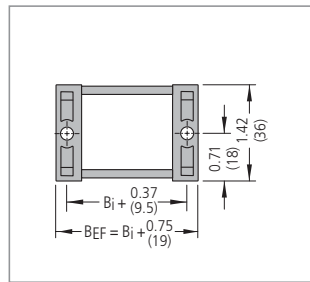
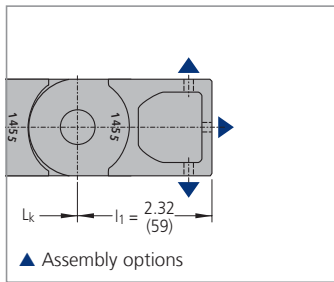

#### UNIFLEX 1555

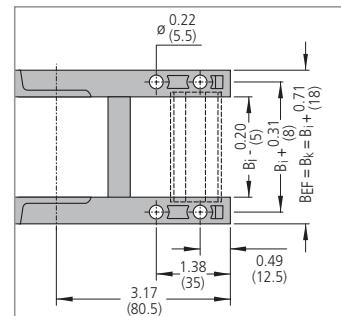
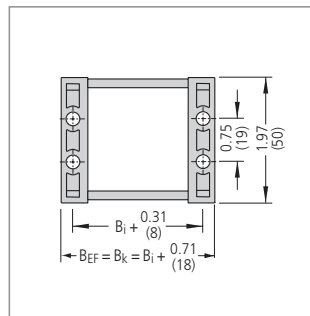
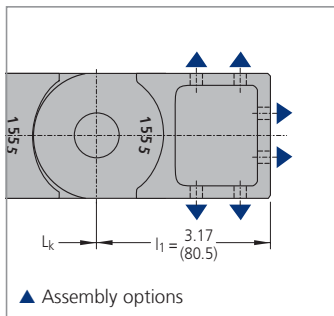

#### UNIFLEX 1665

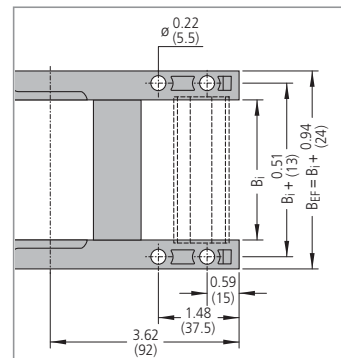
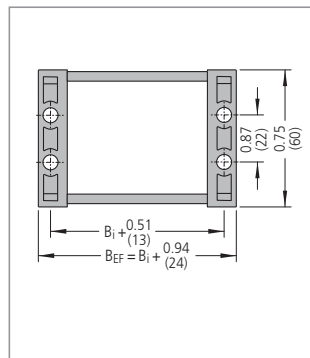
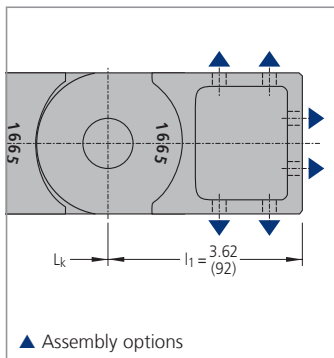

The dimensions of the fixed end and moving end brackets are identical.  
 When ordering please specify the bracket type and configuration FU/MU.

**1455, 1555, and 1665 Glide Shoe Options: for use in long travel gliding applications**

**Replaceable glide shoes – the economical solution for gliding applications (Types 1455, 1555, 1665)**

**Replaceable glide shoes made of plastic**

To extend the life of cable carriers in gliding operations KABELSCHLEPP supplies detachable, exchangeable glide shoes.

Replaceable glide shoes are a very economical solution. When wear occurs only the glide shoes are replaced, and not the complete cable carrier.

Glide shoes are made of a highly wear-resistant, special material.



**Chain height with glide shoes:**

- 1455:  $h_G' = h_G + 0.10'' (2.5) = 1.52'' (38.5)$
- 1555:  $h_G' = h_G + 0.12'' (3.0) = 2.09 (53)$
- 1665:  $h_G' = h_G + 0.12'' (3.0) = 2.48 (63)$

**Minimum bend radii when using glide shoes:**

- 1455:  $KR_{min} = 2.56'' (65 \text{ mm})$
- 1555:  $KR_{min} = 2.15'' (80 \text{ mm})$
- 1665:  $KR_{min} = 3.94'' (100 \text{ mm})$

**Chain width with glide shoes:**

- 1455:  $B_{EF}' = b_j + 0.75'' (19)$
- 1555:  $B_{EF}' = b_j + 0.87'' (22)$
- 1665:  $B_{EF}' = b_j + 1.06'' (27)$

**!** By means of a positive snap connection, the glide shoes sit firmly attached on the chain link.

**1665 Extended Height Frame Stay Options: for use when extra cavity space is required**

**UNIFLEX Advanced 1665 Extended Height Frame Stay**

The extended height frame stay can be used to reliably route cables and hoses with a very large diameter, such as vacuum hoses, where diameters are greater than the clearance height of the standard frame stay cavity.

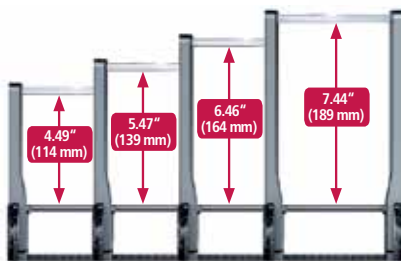

■ Different inside height options for different cable and hose diameters



**Additional chambers for further cables**

Routing of additional cables with small diameters such as electrical or hydraulic cables is also possible in the chambers under the main chamber. Dividers can be used for additional separation of the cables.



**Do you need further information?**  
Please get in touch with us, we will be pleased to help you.



## 1455, 1555, and 1665 Strain Relief Options:

### Strain relief devices

#### One-sided strain relief combs made of plastic (UNIFLEX 1455)

Cables can be fixed securely and simply using the **optional strain relief combs**.

The strain relief combs are installed between the UMBs, and do not need to be bolted on separately or mounted on a C-Rail.

**Please state on the order whether strain relief combs are needed.**



■ Universal mounting bracket with strain relief comb



■ One-sided strain relief comb

$n_z$  = Number of teeth



■ Fixing in the UMB

Type	$B_i$	$n_z$
1455. ....25	0.98 (25)	2
1455. ....38	1.50 (38)	3
1455. ....58	2.28 (58)	5
1455. ....78	3.07 (78)	7
1455. ....103	4.06 (103)	9

#### Both-sided strain relief combs made of plastic (UNIFLEX 1555/1665)

The cables can be fixed securely and simply using the **optional strain relief combs**.

The strain relief combs are installed between the UMBs, and do not need to be bolted on separately or mounted on a C-Rail.

**Please state on the order whether strain relief combs are needed.**

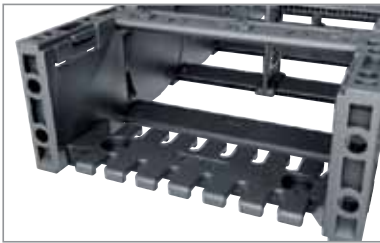

■ Universal mounting bracket with strain relief comb



■ Both-sided strain relief comb



■ Fixing in the UMB

Type	$B_i$	$n_z$
1555. ....50	1.97 (50)	3
1555. ....75	2.95 (75)	5
1555. ....90	3.54* (90)*	6
1555. ....100	3.94 (100)	7
1555. ....125	4.92 (125)	9
1555. ....150	5.91 (150)	11
1665. ....50	1.97 (50)	3
1665. ....75	2.95 (75)	5
1665. ....100	3.94 (100)	7
1665. ....125	4.92 (125)	9
1665. ....150	5.91 (150)	11
1665. ....175	6.89 (175)	13
1665. ....200	7.87 (200)	16
1665. ....225	8.86 (225)*	17
1665. ....250	9.84* (250)*	19

\* on request

$n_z$  = Number of teeth on one side of the comb



## Strain relief devices

### C-rails for LineFix bracket clamps, SZL strain reliefs and clamps (UNIFLEX 1555/1665)

The optional C-rails are fixed by means of the universal mounting brackets and do not have to be screwed separately.

**Please state in your order whether C-rails are needed.**

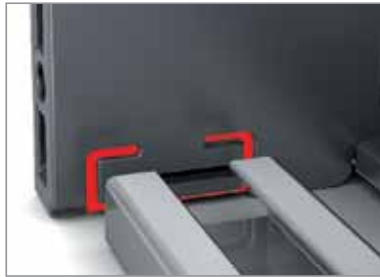

■ Universal mounting bracket with C-rail

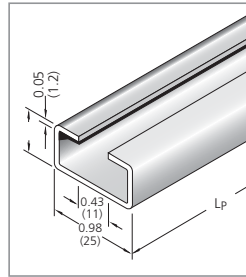

■ Integratable C-rail  
25 x 10 mm,  
slit width 11 mm,  
material steel,  
Item-No. 3931

Our LineFix strain reliefs are optimally suited for the C-rails (LineFix bracket clamps and other strain relief devices).



■ C-rail with LineFix strain relief

